

3i-1706-6B-C

HARDERBACK

Maletas Industriales | Maletines Militares
Estuches de Protección | Cajas Polipropileno
Mochilas Resistentes | Cajas Biométricas



Colores



Especificaciones [Largo x Ancho x Profundo]

Exterior:

[18.20" x 8.98" x 7.30"]
[46.23 x 22.81 x 18.54 cm]

Interior:

[17.00" x 6.50" x 6.50"]
[43.18 x 16.51 x 16.51 cm]

Peso:

[5.20 lb] [2.36 kg]

Certificaciones

MIL-C-4150J / MIL-STD-810F
/ MIL-STD-648C

[Características]

SKB iSeries Moldeado por inyección Mil-Standard
Los estuche impermeables están moldeados de resina de copolímero de polipropileno de muy alta resistencia

- [] Diseño resistente al agua y al polvo
- [] Convenientes ruedas de deslizamiento silencioso
- [] Resistente a los Rayos UV disolventes, corrosión, hongos (MIL-STD-810F).
- [] Válvula de ecuación de presión ambiente
- [] Resistente al daño por impacto (MIL-STD-810F).
- [] Bisagra moldeada para mayor protección

[Configuraciones]

- [] Sin Foam, Vacío
- [] Con Foam precortado

[Accesorios]

- [] 3i-HD80
 - Manijas sobremoldeadas acolchadas.
- [] 1SKB-PDL-C
 - Candado con cable SKB TSA
- [] 3i-TSA-3
 - Cada kit incluye 2 pestillos de bloqueo TSA, pasadores de repuesto y 2 llaves.
- [] 3i-PMCK
 - Panel Mount Clip Kit para los case de la serie 3i
- [] 3SKB-SLP kit
 - Mide 12" x 7" (30.48 x 17.78 cm)



[3i-HD80]



[1SKB-PDL-C]



[3i-TSA-3]



[3i-PMCK]



[1SKB-PDL]



[3SKB-SLP kit]

[CDMX] 55.1328.0711- 55.8851.8725
[WhatsApp] 55 3851 2609
www.seahorse.mx www.harderback.com

HARDERBACK

3i-1706-6B-C

HARDERBACK

Maletas Industriales | Maletines Militares
 Estuches de Protección | Cajas Polipropileno
 Mochilas Resistentes | Cajas Biometricas

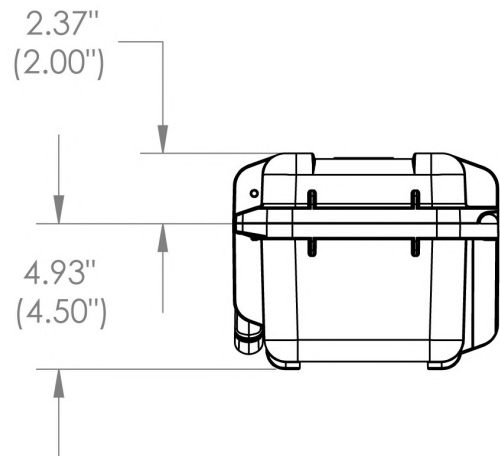
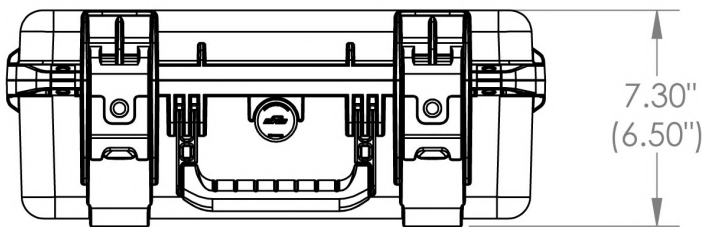
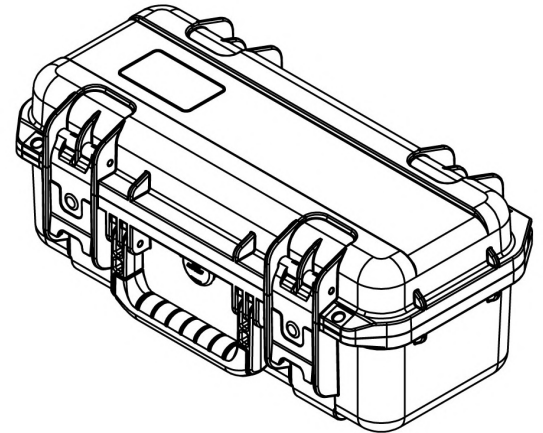
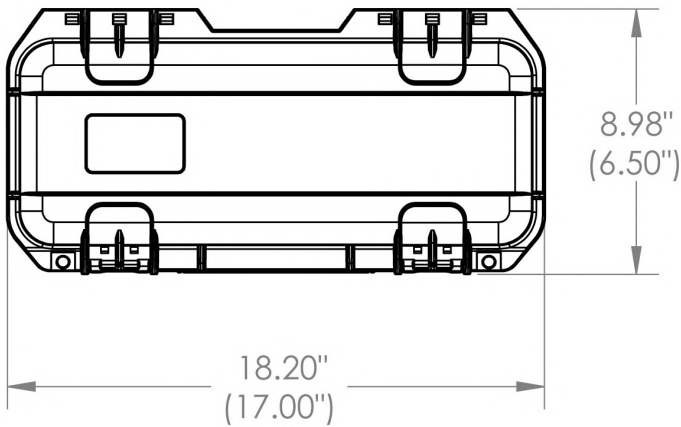

3i-1706-6

NOTE: DIMENSIONS IN (X.XX) ARE ID

Case Series:	3i Series	Dimensions (for reference only)				
		Length	Width	Overall	Base / Lid	
Case part#	3i-1706-6					
		left to right	front to back	height	height	
Weight:	4.8 lbs	Exterior	18.20"	8.98"	7.30"	4.93"-2.37"
		Interior	17.00"	6.50"	6.50"	4.50"-2.00"