

3i-3424-12BC

HARDERBACK

Maletas Industriales | Maletines Militares
Estuches de Protección | Cajas Polipropileno
Mochilas Resistentes | Cajas Biométricas



Colores



Especificaciones (Largo x Ancho x Profundo)

Exterior:

[37.44" x 27.04" x 13.62"]
[95.10 x 68.68 x 34.59 cm]

Interior:

[34.50" x 24.50" x 12.75"]
[87.63 x 62.23 x 32.39 cm]

Peso:

[39.50 lb] [17.92 kg]

Certificaciones

MIL-C-4150J / MIL-STD-810F
/ MIL-STD-648C

[Características]

SKB iSeries Moldeado por inyección Mil-Standard
Los estuche impermeables están moldeados de resina de copolímero de polipropileno de muy alta resistencia

- [] Diseño resistente al agua y al polvo
- [] Convenientes ruedas de deslizamiento silencioso
- [] Resistente a los Rayos UV disolventes, corrosión, hongos (MIL-STD-810F).
- [] Válvula de equalización de presión ambiente
- [] Resistente al daño por impacto (MIL-STD-810F).
- [] Bisagra moldeada para mayor protección

[Configuraciones]

- [] Sin Foam, Vacío
- [] Con Foam precortado

[Accesorios]

- [] 3SKB-BB61
 - Bolsillo con medidas 20" x 15.5" x 3"
- [] 1SKB-PDL-C
 - Candado con cable SKB TSA
- [] 3i-TSA-3
 - Cada kit incluye 2 pestillos de bloqueo TSA, pasadores de repuesto y 2 llaves.
- [] 3i-PMCK
 - Panel Mount Clip Kit para los case de la serie 3i
- [] 3SKB-SLP kit
 - Mide 12" x 7" (30.48 x 17.78 cm)



[3SKB-BB61]



[1SKB-PDL-C]



[3i-TSA-3]



[3i-PMCK]



[1SKB-PDL]



[3SKB-SLP kit]

[CDMX] 55.1328.0711- 55.8851.8725
[WhatsApp] 55 3851 2609
www.skbcases.com.mx www.harderback.com

HARDERBACK

3i-3424-12BC

HARDERBACK

Maletas Industriales | Maletines Militares
 Estuches de Protección | Cajas Polipropileno
 Mochilas Resistentes | Cajas Biometricas

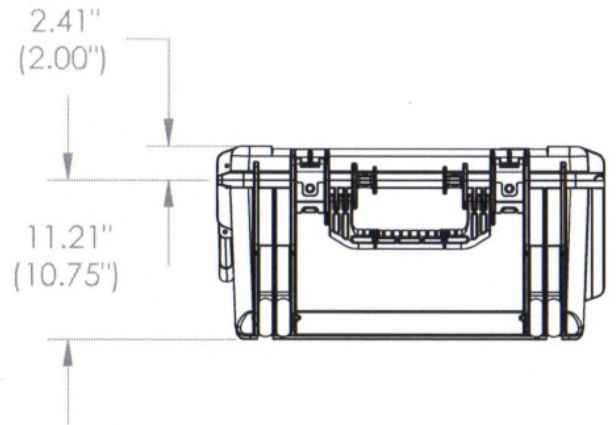
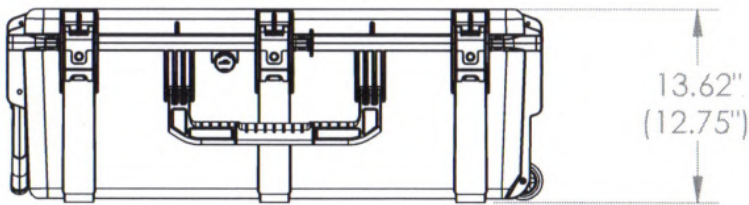
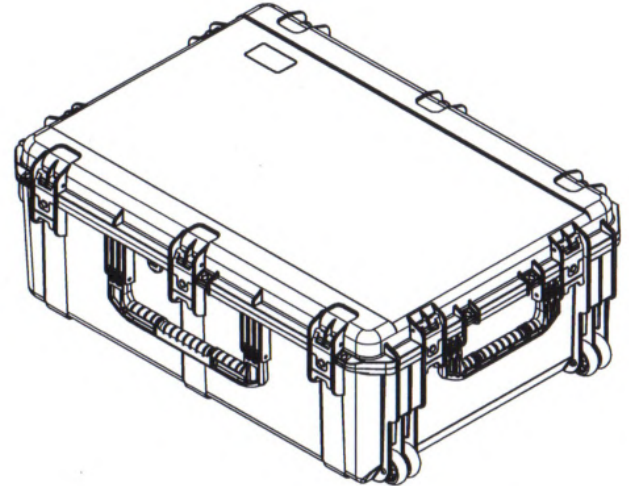
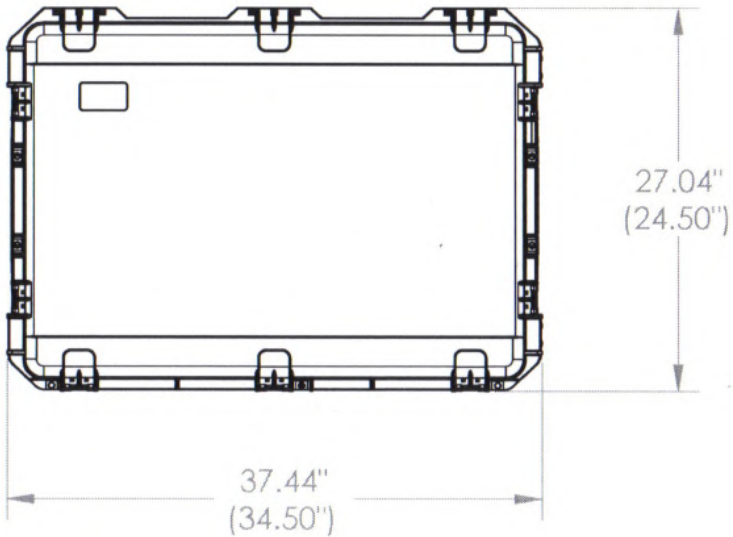

3i-3424-12

NOTE: DIMENSIONS IN (X.XX) ARE ID

Case Series:	3i Series	Dimensions (for reference only)				
		Length	Width	Overall	Base / Lid	
Case part#	3i-3424-12	left to right	front to back	height	height	
Weight:		Exterior	37.44"	27.04"	13.62"	11.21"-2.41"
		Interior	34.50"	24.50"	12.75"	10.75"-2.00"