

3R7408-8B-EW

HARDERBACK

Maletas Industriales | Maletines Militares
Estuches de Protección | Cajas Polipropileno
Mochilas Resistentes | Cajas Biométricas



Colores



Especificaciones [Largo x Ancho x Profundo]

Exterior:

[77.30" x 11.00" x 9.40"]
[196.34 x 27.94 x 23.88 cm]

Interior:

[74.00" x 8.00" x 8.00"]
[187.96 x 20.32 x 20.32 cm]

Peso:

[29.91 lb] [13.57 kg]

Certificaciones

MIL-C-4150J / MIL-STD-810F

[Características]

Estos Cases Mil-Standard fueron diseñados para cumplir con las especificaciones militares más exigentes.

- Diseño impermeable y resistente al polvo.
- LLDPE Polietileno resistente al impacto.
- Resistente a los Rayos UV, solventes, corrosión, hongos (MIL-STD-810F).
- Alivio de presión / válvulas de ventilación.
- Resistente al daño por impacto (MIL-STD-810F).
- Cierres y bisagras de acero inoxidable.

[Configuraciones]

- Sin Foam, Vacio

[Accesorios]

- 3SKB-SLP kit
 - Se ajusta a la serie 3R y Shock Racks
 - Montaje en acero inoxidable.
 - Incluye tornillos, arandelas selladas de goma y tuercas nylock.
 - Mide 12" x 7" (30.48 x 17.78 cm)



[3SKB-SLP kit]



[3SKB-SLP kit]

[CDMX] 55.1328.0711- 55.8851.8725
[WhatsApp] 55 3851 2609
www.skbcases.com.mx www.harderback.com

HARDERBACK

3R7408-8B-EW

HARDERBACK

Maletas Industriales | Maletines Militares
 Estuches de Protección | Cajas Polipropileno
 Mochilas Resistentes | Cajas Biometricas

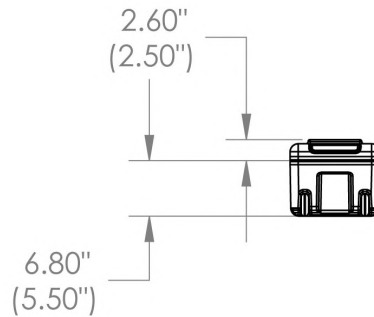
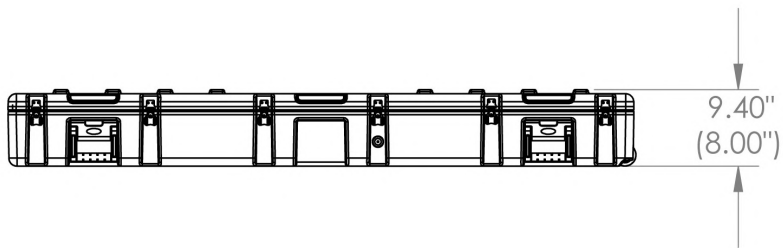
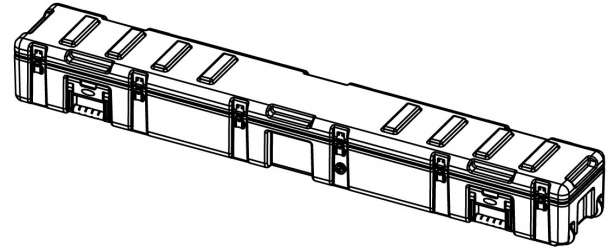
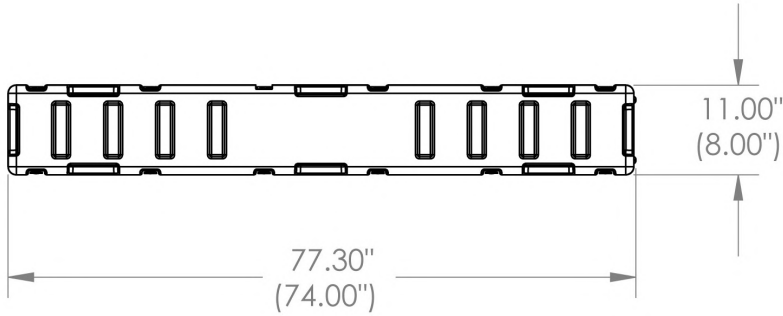

3R7408-8

NOTE: DIMENSIONS IN (X.XX) ARE ID

Case Series:	Military Cases	Dimensions (for reference only)				
		Length	Width	Overall	Base / Lid	
Case part#	3R7408-8	left to right	front to back	height	height	
Weight:		Exterior	77.30"	11.00"	9.40"	6.80"-2.60"
		Interior	74.00"	8.00"	8.00"	5.50"-2.50"